

### 1. 適用範圍 / SCOPE

此份規格書涵蓋 HTE0805/1206/2010/2512/3008-Auto series 金屬陶瓷電流感測電阻元件相關規格。  
This specification covers HTE0805/1206/2010/2512/3008-Auto series, which are Metal Foil Current Sensing Resistor.

### 2. 產品型號/TYPE NUMBER

HTE	0805/1206/2010/ 2512/3008	C	xWx	Rxxx	*	*	Auto
	(1)	(2)	(3)	(4)	(5)	(6)	(7)

- (1) 產品系列號 / SERIES NUMBER : Ex.HTE0805 = 長電極/ long electrode ; 兩端子 / two terminal ; 有側導 / side electrode ; 尺寸 / size “0.08×0.05”
- (2) 產品材質 / Material : C = 鎳銅合金 / NiCu alloy
- (3) 產品瓦特數 / Power Rating : Ex. 1W0=1.0 Watt
- (4) 產品阻值 / Nominal Resistance Value : Ex. 5mΩ → R005 ; 10mΩ → R010
- (5) 元件電阻偏差值 / Resistance Tolerance : Ex. D=±0.5% ; F=±1%
- (6) 產品碼/Product code:Ex. G→Dimension size ; blank→Original design
- (7) 產品碼/Product code:Ex. Auto : For Automotive only and AEC-Q200 qualified

### 3. 產品尺寸 / PRODUCT DIMENSIONS



圖 1 / Fig.1

Unit(mm)

Part Number	W	L	T	A
HTE0805C1W0-series R002~R500-Auto	2.10±0.20	1.35±0.20	0.65±0.20	0.43±0.20

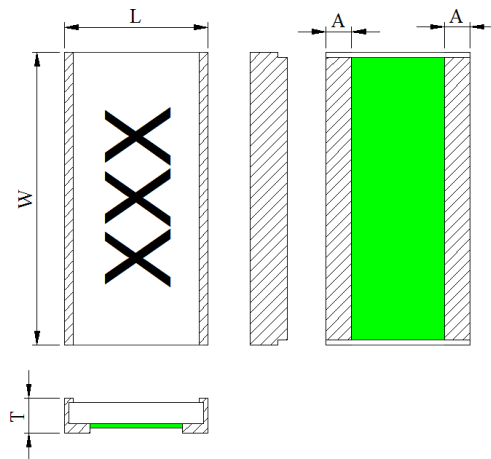

圖 2 / Fig.2

Unit(mm)

Part Number	W	L	T	A
HTE1206C1W5-series R002~R004-Auto	3.30±0.20	1.70±0.20	0.65±0.20	0.50±0.20
HTE1206C1W5-series R005~R100-Auto	3.30±0.20	1.70±0.20	0.65±0.20	0.40±0.20

Part Number	W	L	T	A
HTE2010C2W0-series R002~R100-Auto	5.10±0.20	2.60±0.20	0.65±0.20	0.65±0.20

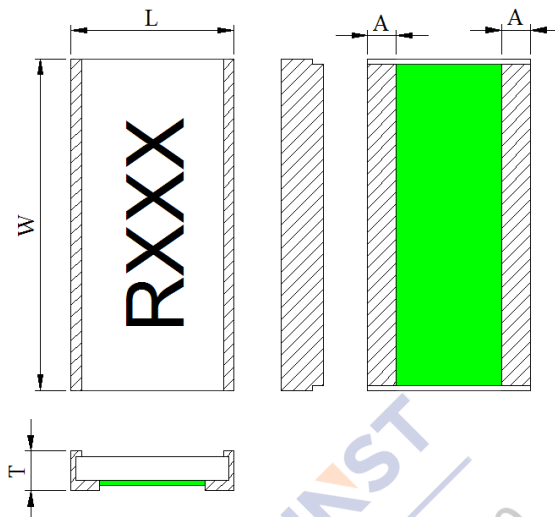
Part Number	W	L	T	A
HTE2512C3W0-series R001-Auto	6.40±0.30	3.20±0.30	0.65±0.20	1.25±0.20
HTE2512C3W0-series R002~R100-Auto	6.40±0.30	3.20±0.30	0.65±0.20	0.60±0.20

Part Number	W	L	T	A
HTE3008C3W0-series R001-Auto	7.60±0.30	2.60±0.30	0.65±0.20	0.75±0.30
HTE3008C3W0-series R002~R100-Auto	7.60±0.30	2.60±0.30	0.65±0.20	0.68±0.30

4. 產品結構及使用材料說明 (參考圖 3) / STRUCTURE & MATERIAL (Ref to Fig.3)



圖 3 / Fig.3

- 4.1 基板 / Substrate(1) : 氧化鋁陶瓷基板 / Alumina Ceramic
- 4.2 粘著層 / Adhesion layer(2) : 環氧樹脂 / Epoxy
- 4.3 電阻本體 / Resistive element(3) : 銅合金 / Cu – alloy
- 4.4 端電極 / Terminal electrode(4) : 錫、鎳、銅 / Sn、Ni、Cu
- 4.5 保護防焊層 / Protective coating(5) : 防火級環氧樹脂,符合 UL- 94-V0 要求(綠色) /  
Flame-retardant epoxy, meets UL- 94-V0 requirements(green)
- 4.6 文印防焊層 / Marking coating(6) : 防火級環氧樹脂,符合 UL- 94-V0 要求(黑色) /  
Flame-retardant epoxy, meets UL- 94-V0 requirements (black)

## 5. 電氣特性 / ELECTRICAL CHARACTERISTICS

Part Number	Resistance Value (mΩ)	Power Rating (Watt)	Resistance Tolerance (%)	TCR (ppm/°C)
HTE0805-Auto series R002~R500	2~9	1.0	±1%(F)	±100
	10~500	1.0	±0.5%(D) / ±1%(F)	±50

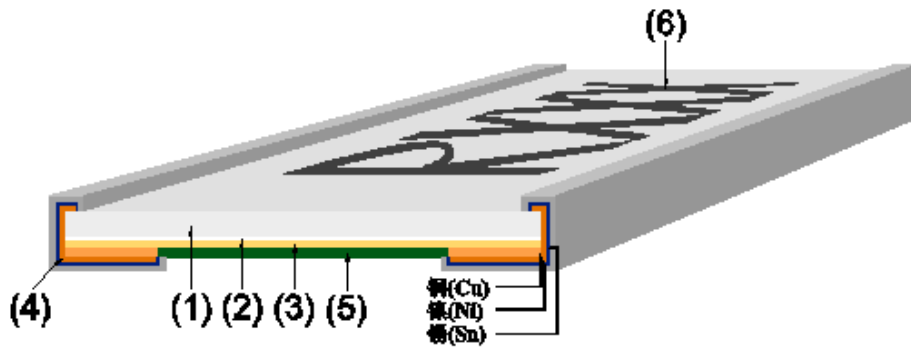
Part Number	Resistance Value (mΩ)	Power Rating (Watt)	Resistance Tolerance (%)	TCR (ppm/°C)
HTE1206-Auto series R002~R100	2~9	1.5	±1%(F)	±100
	10~100	1.5	±0.5%(D) / ±1%(F)	±50

Part Number	Resistance Value (mΩ)	Power Rating (Watt)	Resistance Tolerance (%)	TCR (ppm/°C)
HTE2010-Auto series R002~R100	2~9	2.0	±1%(F)	±100
	10~100	2.0	±0.5%(D) / ±1%(F)	±50

Part Number	Resistance Value (mΩ)	Power Rating (Watt)	Resistance Tolerance (%)	TCR (ppm/°C)
HTE2512-Auto series R001~R100	1~9	3.0	±1%(F)	±100
	10~100	3.0	±0.5%(D) / ±1%(F)	±50

Part Number	Resistance Value (mΩ)	Power Rating (Watt)	Resistance Tolerance (%)	TCR (ppm/°C)
HTE3008-Auto series R001~R100	1~9	3.0	±1%(F)	±100
	10~100	3.0	±0.5%(D) / ±1%(F)	±50

規格外阻值可依客戶需求提供 / We can provide other resistance value per request

6. 產品特性及信賴性測試規範 / PRODUCT CHARACTERISTICS AND RELIABILITY TEST STANDARD

測試方法 Parameter	條件 Conditions	允收標準 Requirements
高溫測試 / High Temp. Exposure	T = +155±2°C ; t = 1000h	±(1.0%+0.5mΩ) MIL-STD-202 Method 108
冷熱衝擊測試 / Thermal Shock	-55±3°C to 155±3°C with 30 minute dwell at each temperature and 1 min maximum transition time.1000 cycles. -55±3°C 至 155±3°C, 每個溫度值的停留時間為 30 分鐘, 每個溫度之間的切換必須在 1 分鐘內完成 .進行 1000 個循環	±(1.0%+0.5mΩ) JESD22-A-104
偏高濕度測試 / Biased Humidity	85°C / 85%RH;10% of operating power, 1000h	±(1.0%+0.5mΩ) MIL-STD-202 Method 103
負載壽命測試 / Operational Life	35% rated power ; T=125±2°C ;t= 90min ON , 30min OFF,1000h	±(1.0%+0.5mΩ) MIL-STD-202 Method 108
可焊性測試 / Solderability	浸入錫爐 / Dip into solder at T = 245±5°C , t = 3±1sec.	錫涵蓋面積/The covered area >95% J-STD-002
抗焊接熱測試 / Resistance to Solder Heat	Condition B, 260±5°C	±(1.0%+0.5mΩ) MIL-STD-202 Method 210 Condition B
機械衝擊測試 / Mechanical Shock	加速度 a =100G , 振幅時間 t = 6 ms a =100G , t = 6 ms	±(1.0%+0.5mΩ) MIL-STD-202 Method 213 Condition C
基板彎曲測試 / Substrate Bending	兩支撐點間距 / Span between fulcrums : 90mm ; 振幅 / Bend Width: 2mm ; 時間 /Time: 60s 測試板/Test board: 玻璃纖維板/Glass-Epoxy Board ; 厚度 / Thickness =1.6mm	±(1.0%+0.5mΩ) AEC Q200-005
溶劑抵抗/ Resistance to Solvents	Add Aqueous wash chemical-OKEM Clean or equivalent, at normal temperature 300 sec in isopropyl.	Without mechanical damage and distinct damage in appearance MIL-STD-202 Method 215

振动测试/ Vibration	5g's for 20 min., 12 cycles each of 3 orientations. Test from 10-2000Hz.	±(1.0%+0.5mΩ) MIL-STD-202 Method 204
静电放电/ESD	Subjected to ESD pulses at 22°C±5°C.	±1.0% AEC Q200-002
推力测试/ Terminal Strength	Force of 1.8kg for 60 Second.	±(1.0%+0.5mΩ) AEC Q200-006
可燃性/Flammability	UL94 V-0 or V-1	UL94
阻燃性/Flame Retardance	32VDC(500ADC)	AEC Q200-001

## 7. 環境特性 / ENVIRONMENTAL CHARACTERISTIC

### 7.1 操作溫度範圍: -55°C ~ 155°C / Operating Temperature: -55°C ~ 155°C

#### 額定功率溫度衰變曲線 / Typical Thermal Derating Curve

額定功率乃指於 70 °C 以內可連續滿額功率使用的術語。

下圖為當操作溫度高於 70°C 時的可使用功率衰減曲線。

Power rating is based on continuous full load operation at rated ambient temperature of 70 °C. For resistors operated at ambient temp. in excess of 70 °C, the max. load shall be derated in accordance with the following curve.

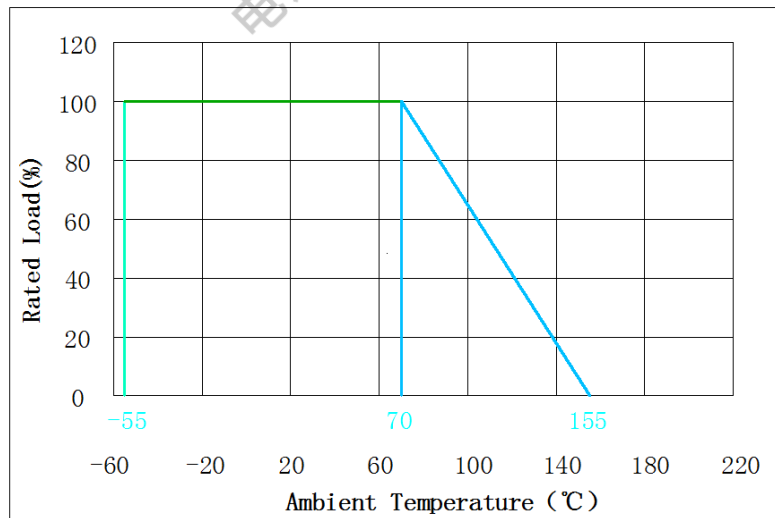

### 7.2 存儲條件 / STORAGE CONDITIONS

在溫度+10°C ~ 40°C、相對濕度 ≤ 75% 的密閉條件下可存放2年。 /

Under airtight in temperature +10°C ~ 40°C、relative humidity ≤ 75% can store 2 years.

在溫度+10°C ~ 60°C、相對濕度為95%的非露天下最多可存放30天。 /

Without dew in temperature +10°C ~ 60°C、relative humidity be 95% maximum value for 30days.

## 8. 焊錫墊尺寸及焊接條件 / SOLDER PAD SIZE AND WELDING CONDITIONS

### 8.1 建議如下圖焊接方式焊接，並滿足所要求的尺寸。 / Propose that the following picture installation

way is installed, and satisfied the required size.

Part Number	P	W	D	Loading
HTE0805-Auto series R002~R100	0.50mm	2.30mm	1.15mm	1.0w

Part Number	P	W	D	Loading
HTE1206-Auto series R002~R004	0.50mm	3.68mm	1.35mm	1.5w
HTE1206-Auto series R005~R100	0.60mm	3.68mm	1.30mm	1.5w

Part Number	P	W	D	Loading
HTE2010-Auto series R002~R100	1.00mm	5.75mm	2.25mm	2.0w

Part Number	P	W	D	Loading
HTE2512-Auto series R001	0.60mm	7.25mm	2.75mm	3.0w
HTE2512-Auto series R002~R100	1.40mm	7.25mm	2.35mm	3.0w

Part Number	P	W	D	Loading
HTE3008-Auto series R001	0.90mm	8.63mm	2.30mm	3.0w
HTE3008-Auto series R002~R100	0.95mm	8.63mm	2.28mm	3.0w

loading : 適用於本公司建議焊墊設計並使用於限定穩定電流下 /  
suit for specific pad layout and specific steady current

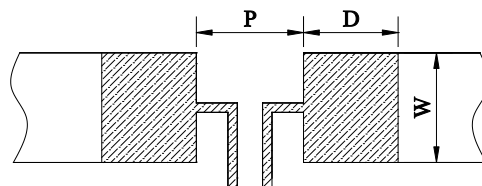

## 8.2 建議客戶焊接參數 / Recommended Customer Soldering Parameters

### 8.2.1 回流焊溫度曲線 / Solder reflow Temperature condition (圖 4 / Fig.4)



圖4 / Fig.4

8.2.2 允許烙鐵焊接條件(熱風設備) / Rework temperature (hot air equipment) : 350°C, 3~5seconds

8.2.3 焊接方法建議 / Recommended reflow methods

焊接熱源方式可用紅外線, 熱蒸氣, 熱風. / IR, vapor phase oven, hot air oven

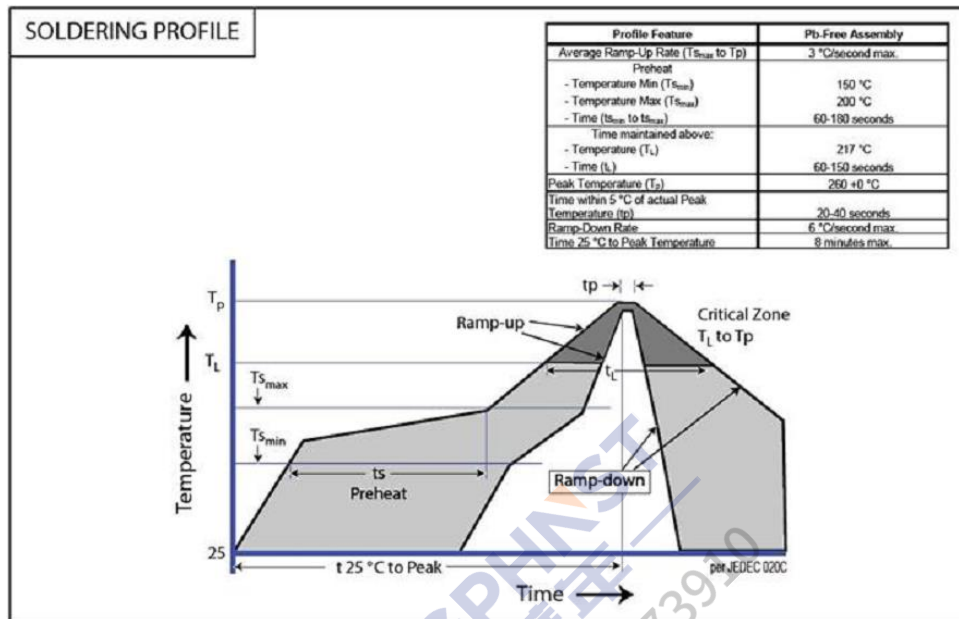
如果焊錫溫度超過允許最高溫度, 則產品本身會有功能損壞的疑慮. / If reflow temperatures exceed the recommended profile, devices may not meet the performance requirements.

## 9. 批量生產後出貨測試項目 / Lot ACCEPTANCE TEST REQUIREMENTS

每一批生產均須作入庫檢驗, 每一批生產單量不可超過500Kpcs. /

Qualification shall consist of passing a program of following tests. Parts shall be pulled from each lot and maximum lot quantity shall be within 500Kpcs.

### 9.1 外觀 / Visual

方法 / Procedure : 利用放大鏡進行檢查 / Visual

標準 / Acceptance Criteria : 不能有髒汙、不潔、文印錯誤、破損等 / No parts are outstandingly stained

### 9.2 尺寸 / Dimensions

方法 / Procedure : 使用合適且經校正的尺規 / As appropriate, calipers, micrometers, optical comparator, or approved gages

標準 / Acceptance Criteria : 尺寸均在規定標準範圍內 / No parts outside specific dimensions

### 9.3 單體元件電阻( $R_o$ ) / Resistance ( $R_o$ )

方法 / Procedure : 在 25°C 下利用四線量測技術量測之 / Resistance shall be measured with 25 °C in the 4-wire resistance test

標準 / Acceptance Criteria : 電阻值均在規定標準範圍內 / The resistance of the test device shall be within the limits specified

#### 9.4 電阻溫度係數 / TCR

方法 / Procedure : 利用四線法量測出元件分別在 25°C 及 125°C 下的電阻值, 並將其帶入下面公式中即可得出 TCR 值 / Getting the sampling device resistance values measured in 25°C and 125°C and put them in to the following equation to calculate the TCR

標準 / Acceptance Criteria : 溫度係數值均在規定標準範圍內 / All parts must within the specific  

$$TCR = (R_b - R_a) / R_a \times 1 / (T_b - T_a) \times 10^6$$

#### 9.5 絕緣電阻 / Insulation resistance (Ri)

方法 / Procedure : 利用絕緣測試儀量測 / Resistance between protective layer and resistive shall be measured by high ohm meter

標準 / Acceptance Criteria : 防焊層與電阻本體絕緣電阻至少高於 100MΩ / The resistance of the test device shall over 100MΩ

### 10. 包裝訊息 / PACKAGING INFORMATION

#### 10.1 包裝數量、重量 / QUANTITY & WEIGHT

型號 / Type Number	數量 / Quantity (pcs)	重量 / Weight (g)
HTE0805-Auto series	5,000	150±30
HTE1206-Auto series	5,000	160±40
HTE2010-Auto series	4,000	210±40
HTE2512-Auto series	4,000	270±50
HTE3008-Auto series	4,000	340±50

#### 10.2 捲輪規格 / Reel & Tape specifications

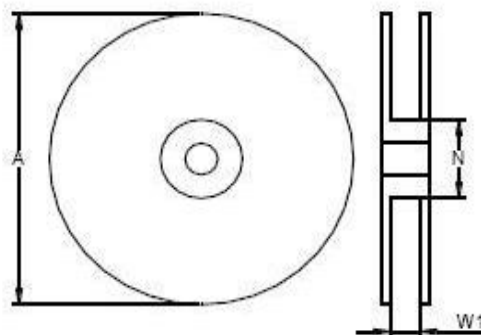



型號 / Type Number	A±5 (mm)	N±2 (mm)	W1±1 (mm)
HTE0805-Auto series	178	60	9.0
HTE1206-Auto series	178	60	9.0
HTE2010-Auto series	178	60	13
HTE2512-Auto series	178	60	13
HTE3008-Auto series	178	60	17

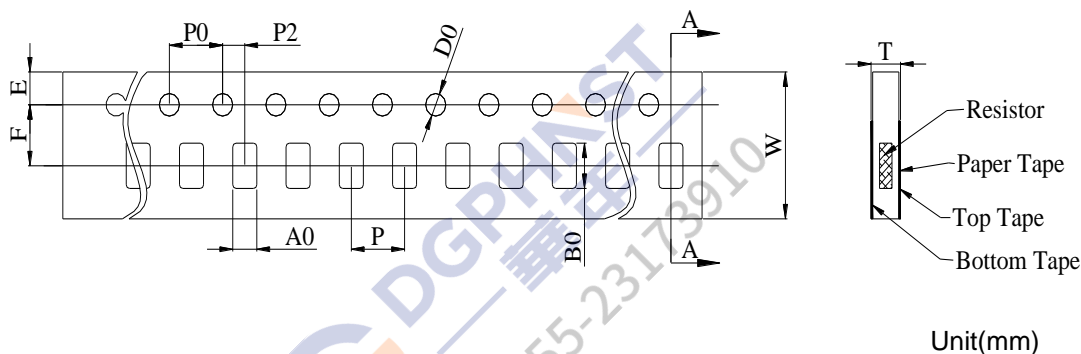

HTE0805-Auto series							
W	8.00 ± 0.30	P0	4.00 ± 0.10	P	4.00 ± 0.10	P2	2.00 ± 0.10
A0	1.55 ± 0.10	B0	2.30 ± 0.10	D0	1.50 ± 0.10	F	3.50 ± 0.10
E	1.75 ± 0.10	T	0.87 ± 0.10	/	/	/	/

HTE1206-Auto series							
W	8.00 ± 0.30	P0	4.00 ± 0.10	P	4.00 ± 0.10	P2	2.00 ± 0.10
A0	2.05 ± 0.20	B0	3.65 ± 0.20	D0	1.50 ± 0.10	F	3.50 ± 0.10
E	1.75 ± 0.10	T	0.87 ± 0.10	/	/	/	/

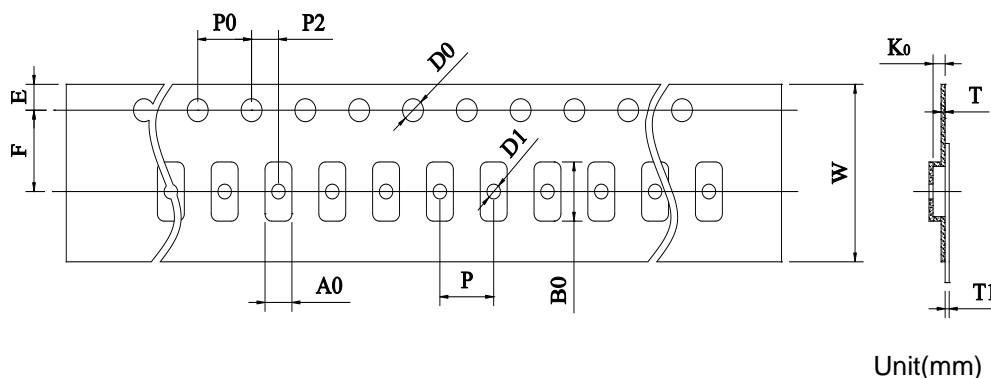

HTE2010-Auto series							
W	12.00 ± 0.30	P0	4.00 ± 0.10	P	4.00 ± 0.10	P2	2.00 ± 0.10
A0	2.85 ± 0.20	B0	5.45 ± 0.20	D0	1.50 ± 0.10	F	5.50 ± 0.10
E	1.75 ± 0.10	T	0.25 ± 0.10	T1	Max. 0.1	K0	0.80 ± 0.20

HTE2512-Auto series							
W	12.00 ± 0.30	P0	4.00 ± 0.10	P	4.00 ± 0.10	P2	2.00 ± 0.10
A0	3.40 ± 0.20	B0	6.75 ± 0.20	D0	1.50 ± 0.10	F	5.50 ± 0.10
E	1.75 ± 0.10	T	0.25 ± 0.10	T1	Max. 0.1	K0	1.00 ± 0.20

HTE3008-Auto series							
W	16.00 ± 0.30	P0	4.00 ± 0.10	P	4.00 ± 0.10	P2	2.00 ± 0.10
A0	2.80 ± 0.20	B0	8.00 ± 0.20	D0	1.50 ± 0.10	F	7.50 ± 0.10
E	1.75 ± 0.10	T	0.30 ± 0.10	T1	Max. 0.1	K0	0.80 ± 0.20

### 10.3 密封膠膜剝離強度要求 / Peeling Strength of Seal Tape

F = 剝離強度 : 0.1 – 1.0N ( 10 - 100gf )

F = Peeling Strength: 0.1 – 1.0N ( 10 - 100gf )

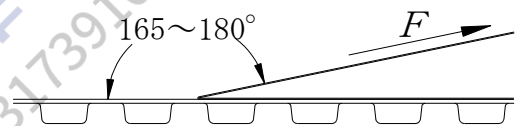

## 11. 其他 / OTHERS

- 11.1 如果在使用中有超出本規格書的要求，必須經由雙方協商確認。 / In the event that an impropriety is found beyond this specification , it shall be fixed by mutual agreement between the parties.
- 11.2 如果本規格書有不適當的情況，必須通過雙方協商並由本公司修改。 / In the event that an impropriety is found in this specification , Juneway Electronic Technology Co., Ltd. shall amend it by mutual agreement between the parties.